

Stratospheric Flight of a Balloon-Borne Solar Cell Testing Facility

*Matteo Gemignani, Francesco Mancini, Salvo Marcuccio**
Dept. of Civil and Industrial Engineering, University of Pisa
Via G. Caruso 8, 56122 Pisa, Italy
matteo.gemignani@phd.unipi.it – salvo.marcuccio@unipi.it
* Corresponding Author

Abstract

Characterizing solar cells in real AM0 environment is cost-effective with respect to ground measurements. For this reason, we designed a balloon-borne test facility to perform I/V curve characterization of solar cells in the stratospheric environment. This paper outlines the design of the facility and the results of a successful first flight that carried three different cells to an altitude of 35 km. The data collected show that peak power is achieved inside the tropopause, where the extreme cold conditions are favorable, rather than at higher altitudes, where - in spite of the higher irradiance - the cells tend to overheat.

1. Introduction

The majority of space vehicles is powered by solar cells. These were introduced with the Vanguard 1 flight made by NASA in 1958 and, since then, have been the standard power production system for spacecraft. At the very beginning, solar panels were not very efficient, but now, with the progresses in electronics and manufacturing processes, they have steadily reached efficiencies of around 30%. Their characteristics are strongly influenced by the spectral composition of the received sunlight and by the thermal conditions they are exposed to. The characterization of the cells in a relevant environment in terms of both spectral irradiance and thermal conditions is of paramount importance in order to understand how they will behave in the actual operational environment [1]. Solar cells manufacturers, in particular, need so-called “primary standard” cells to be characterized in AM0 [2] (Air-Mass zero, i.e., the LEO environment) spectral conditions so to be used later for the calibration of secondary standards and, eventually, of experimental or production units. For cells intended for spacecraft use, the operational environment is not easily reproduced in ground facilities, as an accurate simulation of the solar light spectral features with artificial light sources is difficult and expensive [3]. For such reasons, calibration and testing of solar cells have been performed on zero-pressure stratospheric balloons since the 1960's by the French space agency CNES [4] and the American NASA [5]. Direct comparison showed that the results obtained by testing solar cells on-board of the Space Shuttle were exactly reproduced with high-altitude balloon flights [6].

However, flight opportunities on these balloons onboard of the CNES and NASA facilities remain limited, due to the complexity and cost of large zero-pressure balloon flights. In order to provide a quick, affordable stratospheric cell characterization service, we designed a facility suitable for flying on sounding balloons, named ECAPS (Experimental Characterization of Advanced Photovoltaics in the Stratosphere). The goal of ECAPS is to characterize the performance of various types of solar cells in a stratospheric environment by means of determination of their characteristic current/voltage (I/V) and power/voltage (P/V) curves, focusing particularly on the assessment of closed-circuit current (I_{sc}), open circuit voltage (V_{oc}) and point of maximum power (MPP), and finally correlating these characteristics with local irradiance and with the temperature of the cells themselves. The facility includes an exposed plate hosting a number of solar cells, dedicated I/V curve tracers, and an irradiance sensor, plus environmental sensors to monitor the parameters of the surrounding atmosphere. The system is attached to a helium-filled COTS sounding balloon and flown up to the stratosphere through a 3-hour mission. During the ascending and floating phases of the flight, the I/V curves of the cells under test are continuously recorded, so to allow for comparison of performance of the different photovoltaic technologies in identical, real stratospheric flight conditions, as well as to detect performance changes with external temperature, irradiance, and altitude (as a result of the different spectral balance in sunlight).

2. Mission Design

2.1 Measurement Circuit

An I/V curve (Fig. 1) represents all the possible working points for a solar cell, as a function of the electric load, at given irradiance and temperature. In order to characterize our solar cells, we therefore need an instrumentation capable of measuring the irradiance and the temperature acting on the testing cells. Moreover, we need to make the cell work at all possible loads conditions for those given external inputs. There are several ways to do this [7-9]: the simplest way would be using a variable resistor, but such devices typically work on a limited range of resistance only, hence this design would be good only for a small portion of the I-V curve. More complex designs include a DC-DC converter or a MOSFET. These solutions can bring optimal results but are in general bulky and require complex circuitry. We preferred a simpler but effective design for our Variable Load Circuit (VLC), that relies on the property of capacitors. An empty capacitor behaves as a resistance of zero value (short circuit), while it has essentially infinite resistance when fully charged. Hence, a solar cell that charges a capacitor would span all of its working points. By measuring voltage and current during the charging phase, it is possible to reconstruct the cell I/V curve.

This design has one inherent limitation: the Equivalent Series Resistance of the capacitor, together with the impedance of the wirings and connections, is sufficient to displace the first point of measurement away from its ideal location which should represent the I_{SC} working point of the solar cell. This effect becomes more remarkable as the ratio between I_{SC} and V_{OC} increases, because the maximum power point resistance of the cells decreases and therefore even a small impedance caused by the VLC makes the first point of the measure starting at an offset from the I_{SC} point. The capacitance of the capacitor must be chosen in dependence of the expected current coming from the cell. This comes from a trade-off decision: if the cell outputs a high current, for a given frequency of acquisition of the current/voltage samples, a small capacitor might not be sufficient to collect enough points of measurement along the I/V curve. At the same time, a large capacitor weighs more and needs more time to be charged and discharged, hence slowing down the measurement procedure and reducing the total number of collectable curves for a given flight duration.

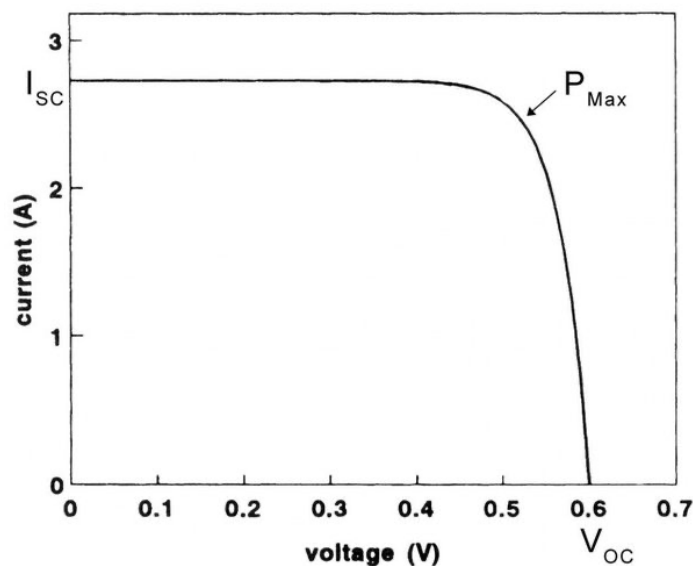

Figure 1: A typical solar cell I/V curve.

Figure 2 shows the main components of each VLC installed on ECAPS. The capacitor is connected to the common (C) terminal of the switching relay. In the closed position (NC), the capacitor discharge is ensured by a bleed resistor. When an I/V curve has to be measured, the relay is switched onto its open (NO) position, so that the cell starts charging the capacitor. During the measurement, the current and the voltage are recorded by means of a 16-bit ADC that measures the voltage drop across a shunt resistor. When the capacitor is fully charged, the relay is closed and the acquisition of the next I/V curve can start. With this configuration, ECAPS is capable of measuring I/V curves of very low-power cells, with voltages up to 5 V and a current resolution of only 9 μ A. Following requests from some of the cell manufacturers, we decided also to add a “high-power” version of this circuit. It essentially utilizes the same architecture but, instead of a 16-bit ADC, a Adafruit INA219 current and voltage sensor [10] is used, that has an extended range in terms of voltage (up to +26 Vdc) and current (up to 3.2 A) with a resolution of 0.8 mA. With these

two VLC versions, ECAPS is able to produce accurate measurements of a large number of different solar cells or modules. Each I/V curves takes only a few seconds to be recorded and about ten seconds to be transmitted to the ground via telemetry. This frequency of acquisition is more than sufficient to capture smooth changes of temperature and irradiance during the ascent of the platform.

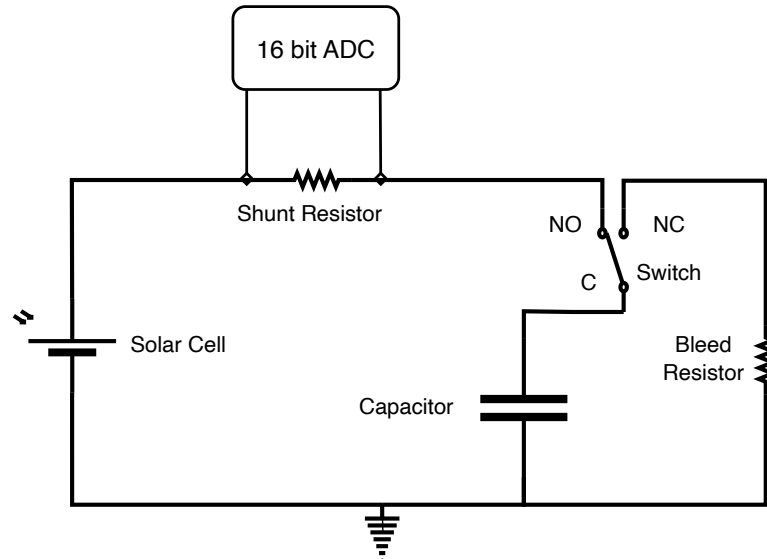

Figure 2: Variable Load Circuit (VLC) layout.

2.2 Architecture of the Facility

The complete architecture of ECAPS, shown in Figure 3, includes three main components: the payload box, the telemetry system and the front panel. The solar cells are mounted on the front panel by means of individual 3D printed frames screwed to the front panel, together with the pyranometer. The data coming from the measurement circuits are collected on a I²C bus by an Arduino UNO controller and relayed via serial communication to a Raspberry Pi3 single board computer. The Raspberry is devoted to the storage of the I/V curves and of all the other relevant data. A miniature IMU (Inertial Measurement Unit) is controlled by the Raspberry. This sensor measures the attitude of the gondola during the flight. In this way we are able to reconstruct the correct cell-to-Sun angle and eventually make corrections to the measured I/V curve. As in balloon flights the possibility of not being able to retrieve the payload after landing cannot be ruled out completely, we decided to add a telemetry system based on a Dragino LoRa shield, which uses the LoRa protocol [11] to send a reduced subsample of the I/V curves. On the ground, we used a Yagi antenna to follow the payload and retrieve the downlinked curves. For the first flight, it was decided not to put any temperature sensor on the solar cells; this is a challenging measurement because it is quite difficult to integrate a temperature sensor right onto a cell with an encapsulation. This should be included in the fabrication process of the cell for an optimal measurement.

Three different cells from Italian institutes and companies were selected for the first flight of ECAPS:

- a CIGS module (Copper-Indium-Gallium-Selenide) thin film solar cell provided by IMEM - CNR, Parma;
- a space-grade triple junction solar cell provided by CESI S.p.A, Milan;
- a perovskite module provided by CHOSE - Università di Tor Vergata, Rome.

The electronics were hosted inside a Styrofoam box to provide insulation and protection against the extreme cold environment of the lower stratosphere. The experiment had a total mass of approximately 1.8 kg. Figures 4 and 5 show the flight-ready facility, moments before launch. The box was attached to the so-called balloon train, composed by a 1600 grams latex balloon, a small parachute and the connecting lines. The balloon, filled with helium, climbs up in the atmosphere until the external pressure drops to an extremely low level, making its envelope stretch to its maximum tension stress and burst. After the bursting, the parachute opens and slowly drives the payload towards the ground. The recovery is possible thanks to a GNSS receiver (namely a SPOT TRACE satellite tracker) installed on the payload that relays the balloon position to the ground once every five minutes and makes it relatively easy to follow by the payload recovery team. The flight sequence is summarized in Figure 6.

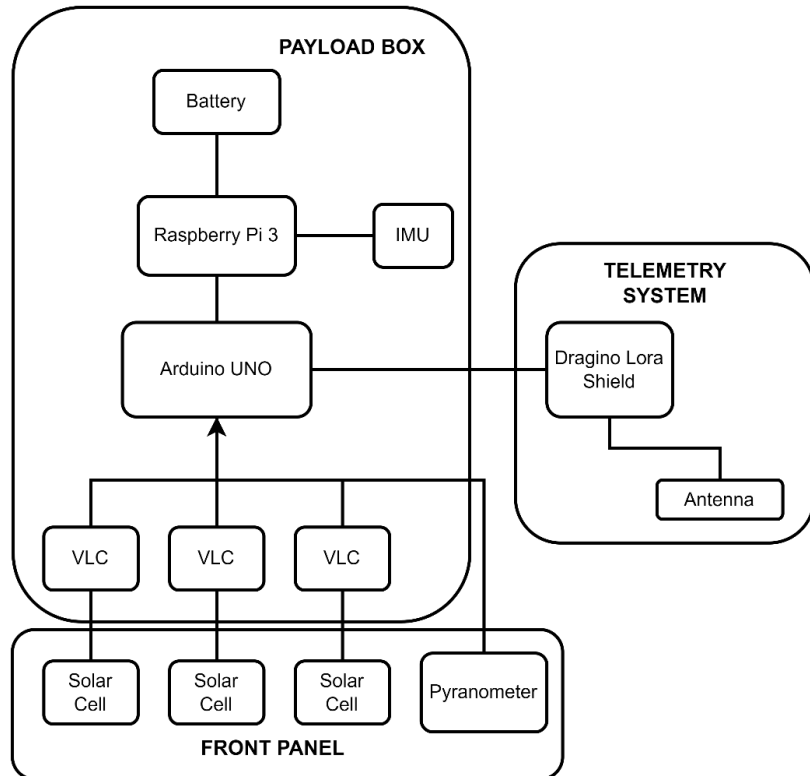

Figure 3: ECAPS Architecture

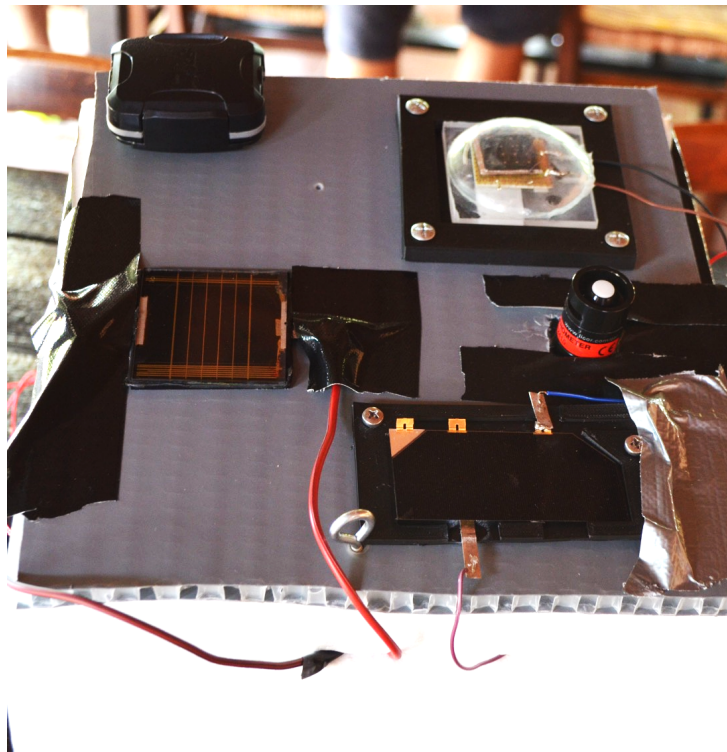

Figure 4: Front plate view of the ECAPS experiment.

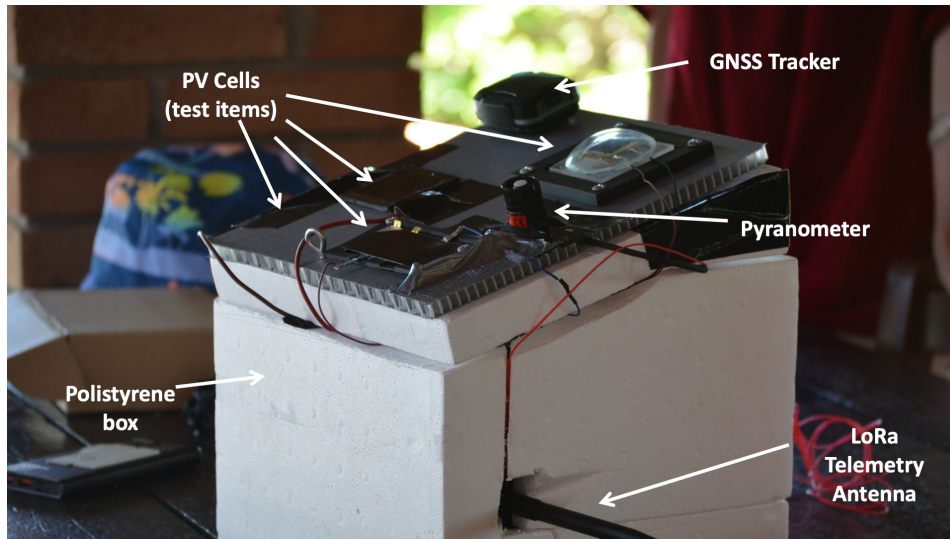

Figure 5: The ECAPS facility ready for flight.

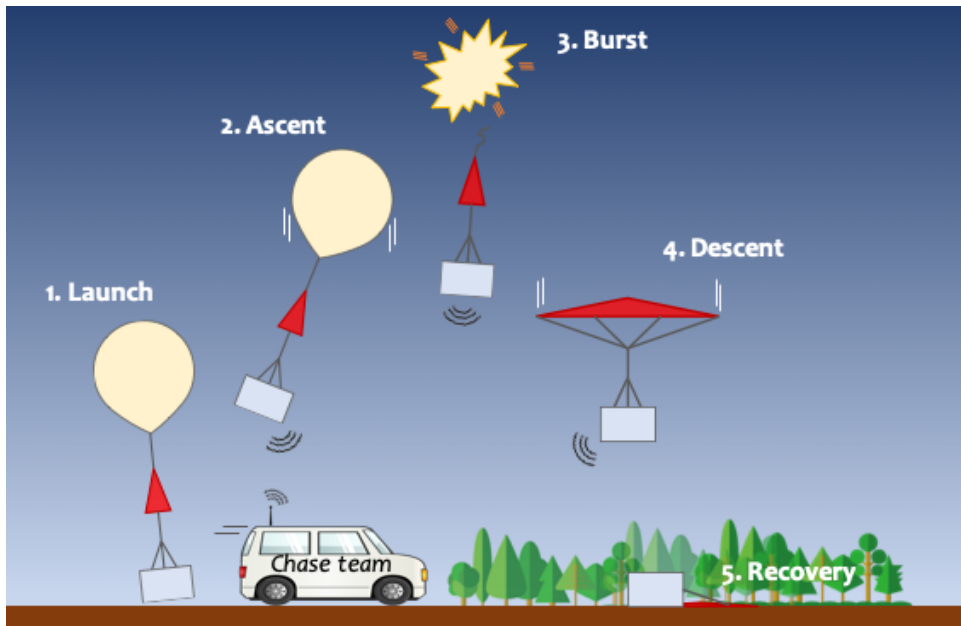

Figure 6: Sequence of events of a sounding balloon mission, from launch to recovery.

3. Mission Results

The experiment was launched successfully on July 29, 2022, from a southern Tuscany location. The balloon achieved a maximum altitude of 35 km, burst, and landed for a total mission duration of 3 hours. The payload ascended at a near constant speed of about 5 m/s. All the instruments on-board worked nominally. The payload was successfully recovered in good conditions a few hours after the landing. A total of 127 curves for each cell were successfully recorded onboard through the ascent of the payload; of those, about 15% were downloaded via telemetry. Figure 7 shows an example of the collected curves for the CESI triple junction solar cell. The data collected for the I_{sc} and V_{oc} of the CESI cell are within less than 1% with respect to the cell nominal (datasheet) values, which demonstrates the quality of ECAPS in performing this kind of characterization. As visible from the plot, the series resistance introduced by the measurement circuit is sufficiently small, so that the first point of the I/V curve still lies in the horizontal zone of the curve and therefore can be considered as an acceptable approximation of the short circuit current value of the cell.

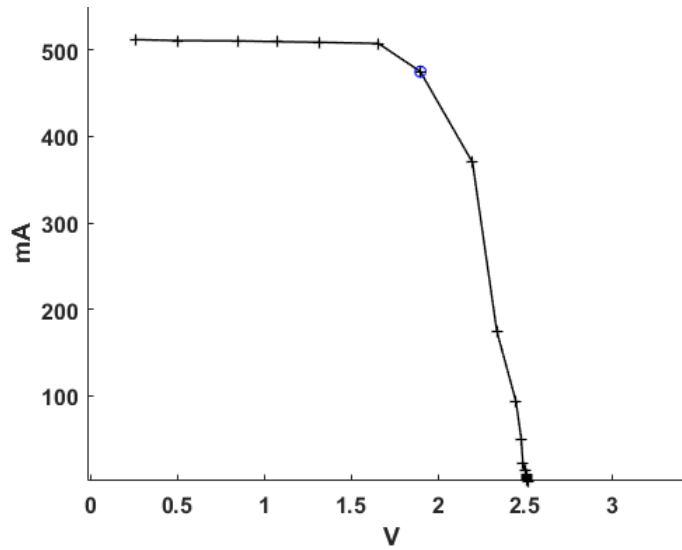

Figure 7: I-V curve acquired by ECAPS, CESI triple junction cell.

The platform was not attitude stabilized, so that the inevitable azimuthal rotation of the gondola resulted in continuous fluctuations of the measured irradiance. The upper envelope of the irradiance data collected by the pyranometer is shown in Figure 8, corresponding to the actual irradiance along the Sun axis. As expected, the irradiance value increased throughout the flight and peaked at around 1325 W m^{-2} . The slight decrease of irradiance recorded at higher altitudes, instead, was not expected and is not readily explained; our present assumption is that the pyranometer could have become misaligned, maybe due to wind action, or alternatively that the reading was affected by the self-heating of the sensor.

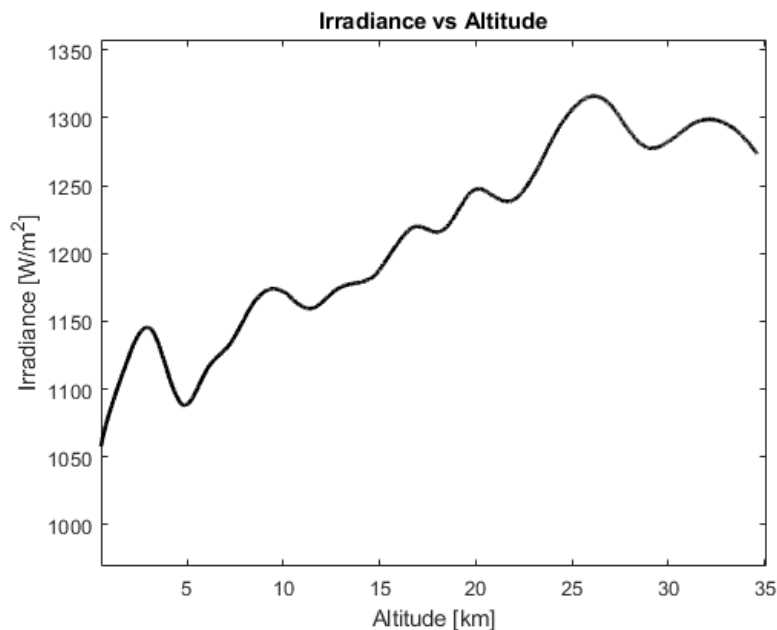

Figure 8: Upper envelope of the recorded irradiance history of the ECAPS flight.

By jointly considering Figures 8, 9 and 12, we deduce that the power produced by the cells did not peak in the correspondence of the maximum irradiance. This is probably because of the effect of temperature, that strongly affects the output power of a solar cells. The temperature primarily influences the voltage: V_{oc} decreases with increasing temperature, while the short circuit current value does not show such large variations. This is clearly visible from the plot: at around 15-16 km, which correspond to 50 min on the horizontal axis, the cells experienced their lowest temperature value. In this condition, their efficiency is at its maximum. After that, while the total irradiance increases, the temperature rises again. This is caused by the ozone UV absorption that occurs at around 23 km which leads to a

rise of the temperatures in the stratosphere. Moreover, at 30 km, almost 99% of the weight of the atmosphere has been passed through, therefore heat convection effects that might cool down the cells are not present anymore. This condition causes the cells to perform worse in the upper part of the flight, while the early tropopause layer of the atmosphere represent the best trade-off for the cells in terms of efficiency. All the other cells on the experiment showed similar results.

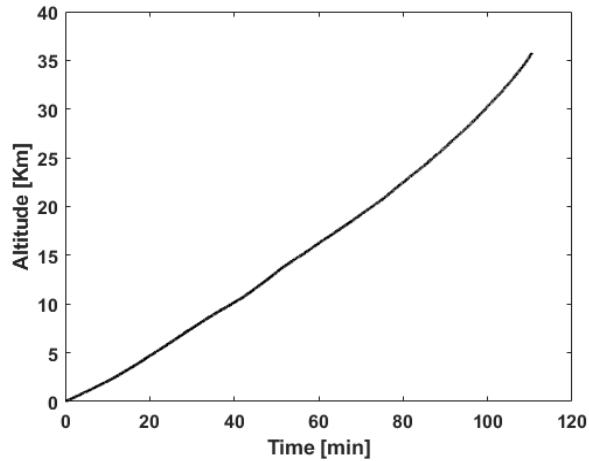

Figure 9: ECAPS altitude history during the ascent

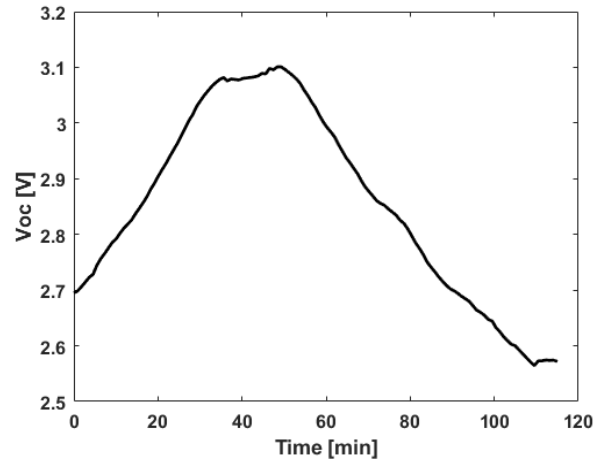

Figure 10: Voc history of CESI 3J cell

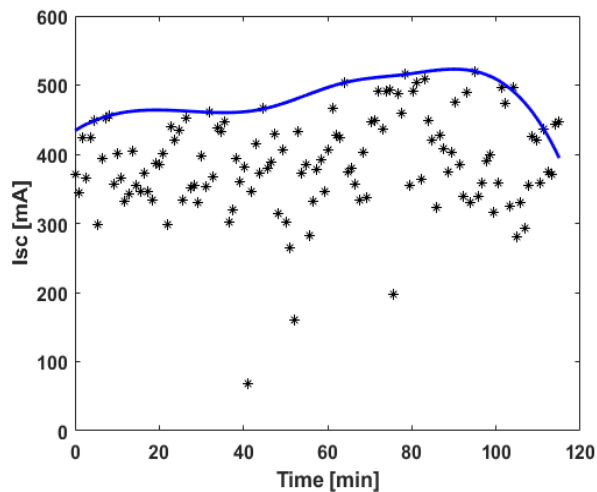

Figure 11: Isc history of CESI 3J cell

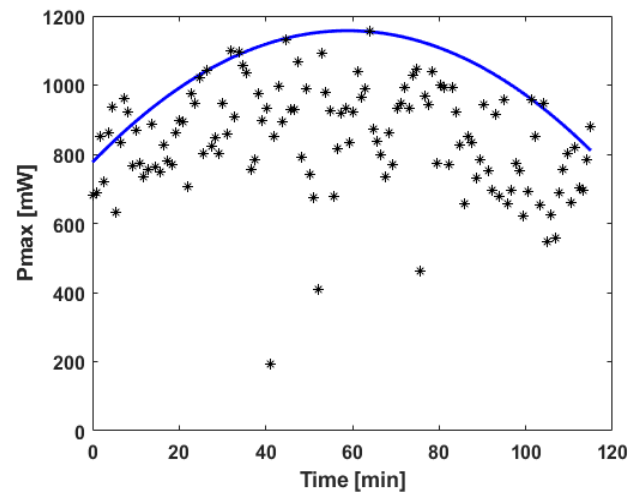

Figure 12: Power produced at maximum powerpoint by CESI 3J cell

4. Conclusions

The first flight of the ECAPS experiment was successful. The retrieved data show very good similarity (within less than 1%) to the data measured on ground by the manufacturers. Moreover, the acquired data suggests that these cells perform better in the lower layers of the tropopause with respect to higher altitudes, even in worse irradiance conditions.

The ECAPS platform can be improved in different ways. An altitude stabilization system would extend the duration of the mission, helping the manufacturers to understand longer time-scale phenomena that may affect the cells performance. Moreover, an attitude stabilization would extend even more the platform capabilities, enabling long duration pointing of the cells towards the Sun. With these improvements, we believe that the ECAPS platform will represent an extremely attractive opportunity for solar cell testing in AM0, near-space conditions, providing a useful service to researchers and manufacturers.

5. Acknowledgments

We thank Dr. Roberta Campesato of CESI S.p.A. for the permission to reproduce experimental data.

References

- [1] P. P. Jenkins et al., “Direct Comparison of Ground and In-Flight Measurements of New Multi-Junction Solar Cell Technologies,” E3S Web of Conferences, vol. 16, p. 02003, May 2017, doi: 10.1051/e3sconf/20171602003
- [2] J. H. Lee et al., “On-orbit characterization of space solar cells on nano-satellites,” in 2016 IEEE 43rd Photovoltaic Specialists Conference (PVSC), IEEE, Jun. 2016, pp. 1331–1336. doi: 10.1109/PVSC.2016.7749832
- [3] Z. Yu, S. Jiajia, L. Tizhao, L. Min, and W. Heying, “AM0 space solar cell calibration method based on GEO satellite,” in 2019 14th IEEE International Conference on Electronic Measurement & Instruments (ICEMI), IEEE, Nov. 2019, pp. 1562–1566. doi: 10.1109/ICEMI46757.2019.9101696
- [4] E. Rapp, V. Pichetto, C. Elisabelar, C. Baur, D. Bausch, and M. Jeunet, “Casolba: Balloon Calibration of Solar Cells,” E3S Web of Conferences, vol. 16, p. 02001, May 2017, doi: 10.1051/e3sconf/20171602001
- [5] J. A. Zoutendyk, “Space Calibration of Standard Solar Cells Using High-Altitude Balloon Flights”, Journal of Spacecraft and Rockets, Vol. 2, No. 3, 1965, pp. 399-404. doi: 10.2514/3.28191
- [6] B. E. Anspaugh, R. G. Downing, and L. B. Sidwell, “Solar Cell Calibration Facility Validation of Balloon Flight Data: A Comparison of Shuttle and Balloon Flight Results”, Technical Report NASA-CR-176528, JPL Publication 85-78, Jet Propulsion Laboratory, Pasadena, CA, October 15, 1985.
- [7] E. Duran, M. Piliougine, M. Sidrach-de-Cardona, J. Galan, and J. M. Andujar, “Different methods to obtain the I/V curve of PV modules: A review”, in: 2008 33rd IEEE Photovoltaic Specialists Conference, IEEE, May 2008, pp. 1–6. doi: 10.1109/PVSC.2008.4922578
- [8] J. I. Morales-Aragonés, M. Dávila-Sacoto, L. G. González, V. Alonso-Gómez, S. Gallardo-Saavedra, and L. Hernández-Callejo, “A Review of I–V Tracers for Photovoltaic Modules: Topologies and Challenges,” Electronics (Basel), vol. 10, no. 11, p. 1283, May 2021, doi: 10.3390/electronics10111283
- [9] A. Asbayou, M. Agdam, A. Aamoume, A. Soussi, A. Ihla, and L. Bouhouch, “Utilization of MOSFET transistor as an electronic load to trace I-V and P-V curve of a solar panel,” E3S Web of Conferences, vol. 229, p. 01021, Jan. 2021, doi: 10.1051/e3sconf/202122901021
- [10] “Overview | Adafruit INA219 Current Sensor Breakout | Adafruit Learning System.” <https://learn.adafruit.com/adafruit-ina219-current-sensor-breakout/overview> (accessed Jul. 03, 2023).
- [11] “Semtech LoRa Technology Overview | Semtech.” <https://www.semtech.com/lora> (accessed Jun. 07, 2023).